

BEST PRACTICES IN **SUSTAINABLE** **BUILDING DESIGN**

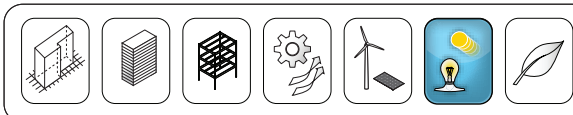

+ **INTERACTIVE LEARNING DVD**

Shahin Vassigh
Ebru Özer
Thomas Spiegelhalter



6. Lighting

6.1 Concepts

An understanding of how light influences our visual perception, needs, and experience of the environment is essential for lighting design in buildings. The effect of lighting on interior space arrangement and identifying the visual needs of occupants for specific tasks are also important to acknowledge. In addition, the designer should consider the value of physiological and psychological effects of brightness, color patterns and aesthetics on visual acuity, particularly in spaces occupied for extended periods.

Measuring Light

Only a small portion of the electromagnetic spectrum in the approximate range of 380–780 nanometers (nm) is visible to the human eye. Visible light is perceived in a variety of colors, from the longest visible wavelength of red (700 nm) to shorter wavelengths of orange, yellow, green, blue, and violet (400 nm). Although white light has an equal mixture of all the wavelengths, black is a result of no light.

LUMINANCE AND BRIGHTNESS Luminance (L) or luminous intensity (LI) is the measurement of light brightness emitting from an object or surface. Luminance also refers to the human perception of the brightness sensation that is reflected off the surface. Brightness is a function of the object's actual luminous intensity, including the reflections of adjacent surfaces and objects. Luminance can be objectively measured by a light meter or photometer. However, the human perception of brightness has individual limitations based on the relative perceiver's physiological and psychological conditions and the influence of colored or reflective surroundings. Luminance units are expressed in candelas or candlepower per square foot (cd/ft^2) or per square meter (cd/m^2).

ILLUMINANCE Illuminance (E) describes the incident and density of light per unit area hitting a given surface or plane. Illumination is commonly known as light level and is measured in foot-candle (fc) or lux (lx). Foot-candle is the U.S. standard unit measuring the illumination of one candlepower or one candela per one square foot of a surface that is one foot away from the light source. Lux is the metric unit (SI) that indicates the illumination of one lumen per square meter that is one meter away from the light source. One lux equals 0.093 foot-candles.

LUMEN OR LUMINOUS FLUX Luminous flux is the monochromatic light portion of the electromagnetic spectrum that is perceived as light

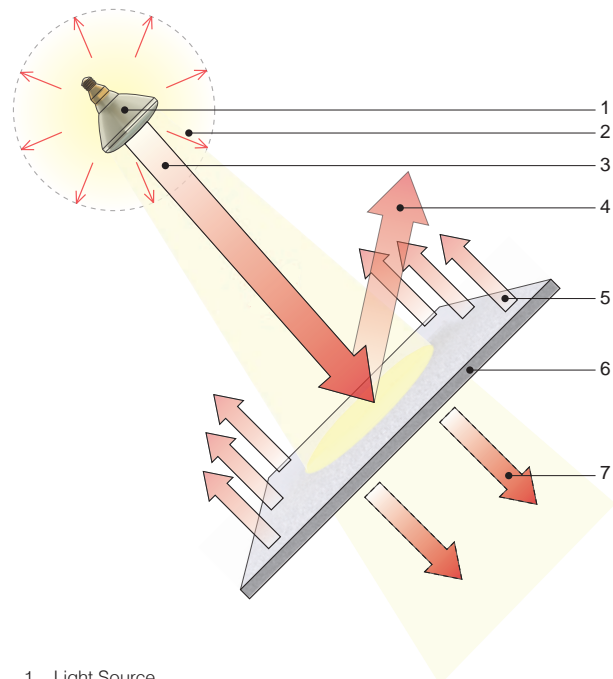

1. Light Source
2. Luminous Flux (Lumen)
3. Luminous Intensity (Candela or Candlepower)
4. Reflected Luminance at Specific Angle (Candela per Square Foot)
5. Illuminance (Foot-Candle or Lux)
6. Translucent Surface
7. Transmitted Luminance at Specific Angle (Candela per Square Foot)

Fig. 6.1-1 Luminance and Brightness



by the human eye. Luminous flux is also called luminous power or photometric power. The unit of luminous flux is the lumen (lm) in both SI and IP units. Lumens express the total light output of a light source and measure the intensity of light emitting or radiating out from a surface. A higher lumen rating indicates a brighter light, but the overall life span of the light source can be different. When using artificial lighting, lumens provide a base for comparing various lighting technologies in terms of their energy consumption, heat generation, overall life-cycle span and costs.

There are some limitations to the human's perception of luminous flux because many light sources are not monochromatic, but produce luminous intensity in different parts of the electromagnetic spectrum. Each light source or luminaire originates from a different location in the electromagnetic spectrum and has its own luminous efficiency rating in lumens/watt.

LUMINOUS EFFICACY Luminous efficacy is the term used to denote lighting efficiency. Luminous efficacy indicates the amount of lumens emitted per watt of electricity consumed. Luminous efficacy measures the perceived brightness of a specific light source in lumens per watt (lm/w). Lumens per watt can be also used to measure the intensity of natural light penetrating through glazing in buildings (depending on the glazing types and properties). Light sources with high luminous efficacy consume less energy while maintaining a high quality of light.



TYPE	MEASUREMENT UNIT
 Incandescent	100 W 1740 Lumens
 Compact Fluorescent	100 W 4500 Lumens
 Fluorescent	100 W 7800 Lumens

Fig. 6.1-2 Examples of Light Output from Different Light Sources

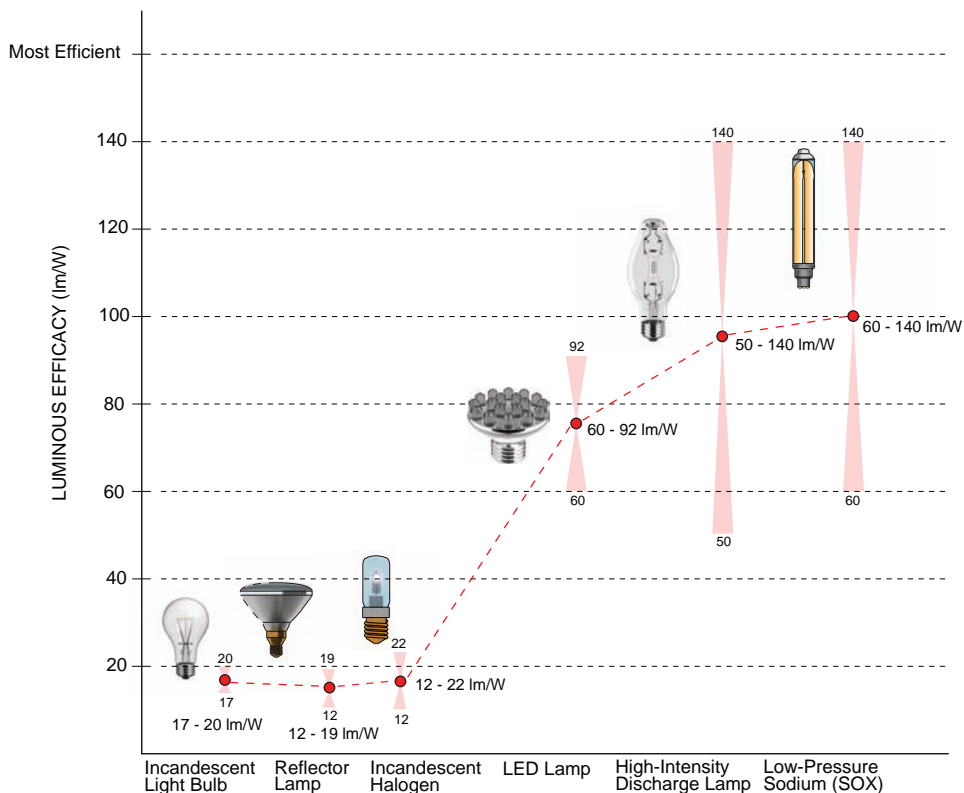
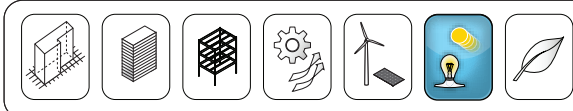

Fig. 6.1-3 Luminous Efficacy for Different Light Sources



6. Lighting

CANDELA Candela (cd) or candlepower (cp) is the SI unit of luminous intensity that measures the rate at which light leaves the incident light source. Candela indicates the amount of light produced by an object in a given direction at a precise frequency. Manufacturers of light sources provide candela distribution graphs, charts or tables for each of their luminaires to indicate the luminous intensity of their lighting products.

CHROMATICITY The color of illumination can be described by chromaticity or correlated color temperature (CCT). Chromaticity refers to the color appearance of a light source. A low CCT indicates a warm color temperature; a high CCT value indicates a cool color temperature. Lighting designers use chromaticity diagrams, spectral energy distribution (SED) or spectral power distribution (SPD) diagrams to determine the different color content and temperature of any light source. Quantifying chromaticity is an attempt of objective measurement of the color value independent of its luminance. Quantifying chromaticity not only involves the color characteristics of one object, but it also involves the various background effects with hue and saturation intensities from low chroma to high chroma areas.



TYPE	MEASUREMENT UNIT
 <p style="text-align: center;">Spot</p>	<p>2000 Lumens 7400 Candlepower/Candela</p>
 <p style="text-align: center;">Flood</p>	<p>2000 Lumens 1100 Candlepower/Candela</p>

Fig. 6.1-4 Examples of Spot and Flood Light Luminous Intensity



6. Lighting

Light Transmittance

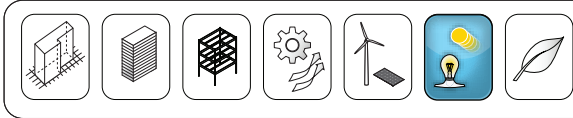
Light rays travel in a straight line from a source at a specific wavelength until they strike a physical surface or a plane. When incident light encounters a medium, it may be transmitted, absorbed, reflected or refracted based on the material properties of that medium. A medium may be transparent, translucent or opaque.

VISIBLE TRANSMITTANCE The amount of light transmitted through glass is called visible transmittance (VT) or visible light transmittance. VT is expressed by a number between zero and one: zero indicating no light passing through and one indicating all the light passing through the glass. VT is influenced by the glass color, the inner and outer coatings and the number of glazing layers. Clear glass has the highest VT, but also produces glare, contrast, and unacceptable heat gain or loss. Adding a tint, or applying a color coating or a reflective film to a glazing surface can reduce the VT. Most glass treatments used for reducing VT also reduce heat gain or loss from the ultraviolet and infrared portion of the solar spectrum. Energy-efficient glazing of façade systems with double low-E (refer to Section 6.2) and triple-pane glazing varies between 0.30 and 0.70.

TOTAL ULTRAVIOLET TRANSMITTANCE Ultraviolet transmittance (UV) occurs between 280 and 380 nm and has potential effects on various glazing materials, objects and fabrics. As a result, an object's protective surface might fade and lose its original character or performance quality. The UV transmittance factor (UV_{tm}) quantifies the ability of glass to reduce fading by measuring the effects of both transmitted UV and visible light. The total UV_{tm} is regulated by the International Standards Organization in the category "Damage Weighted Transmittance (T_{dw}-ISO)" and by the International Commission on Illumination (CIE), an international authority on lighting and illumination.

TOTAL INFRARED TRANSMITTANCE The infrared transmittance (IR) segment of the solar spectrum encompasses wavelengths between 780 and 4000 nm and has a heat radiation impact on a range of transparent materials when surfaces are exposed to intensive IR light. According to the CIE, the IR radiation does not cause fading directly; however, the produced heat by the absorption of IR radiation can significantly influence the fading process. Infrared transmittance is regulated by the International Standards Organization to assess the potential effects of heat impact on glazing materials.

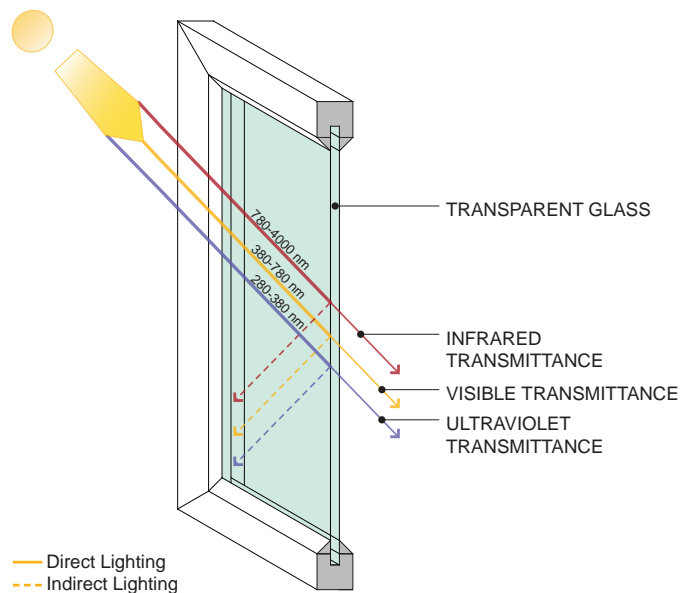

Fig. 6.1-6 Light Transmittance

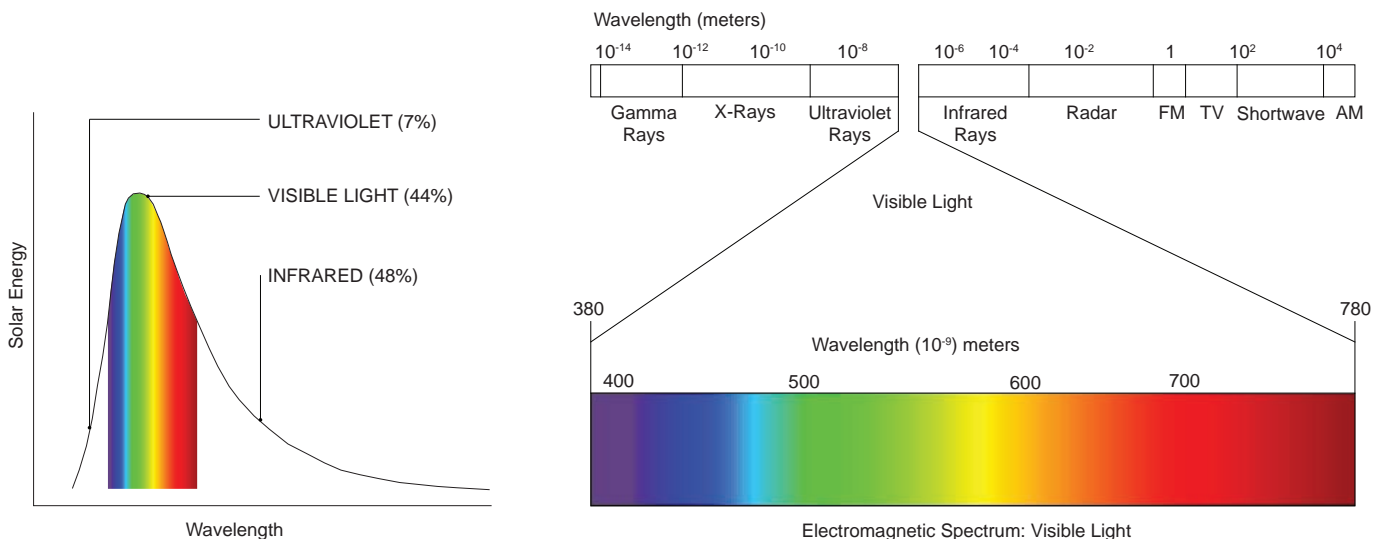
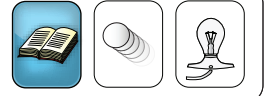

Fig. 6.1-7 Solar Spectrum



REFLECTION When direct light strikes a surface, it bounces or reflects in different paths, depending on the texture of that surface. A highly polished object, such as a mirror, will reflect the light at the same angle as the incident light. This is called specular reflection. Diffused reflection is caused by matte surfaces and light is reflected in all directions. Uneven surfaces or surfaces with irregularities produce a spread reflection.

REFRACTION Light refraction occurs as light travels from one medium to another at different speeds. This causes light to bend and change its direction at the boundary between the two media. For example, when light passes through air (a transparent medium) and enters glass (another transparent medium) it is partially reflected and partially transmitted.

ABSORPTION Absorption refers to the energy from light that is absorbed in the volume of a material. It quantifies how much of the incident light is absorbed or reflected based on the properties of the material. Opaque objects absorb most of the light rays because light cannot pass through them. Opaque materials absorb and reflect all light waves.

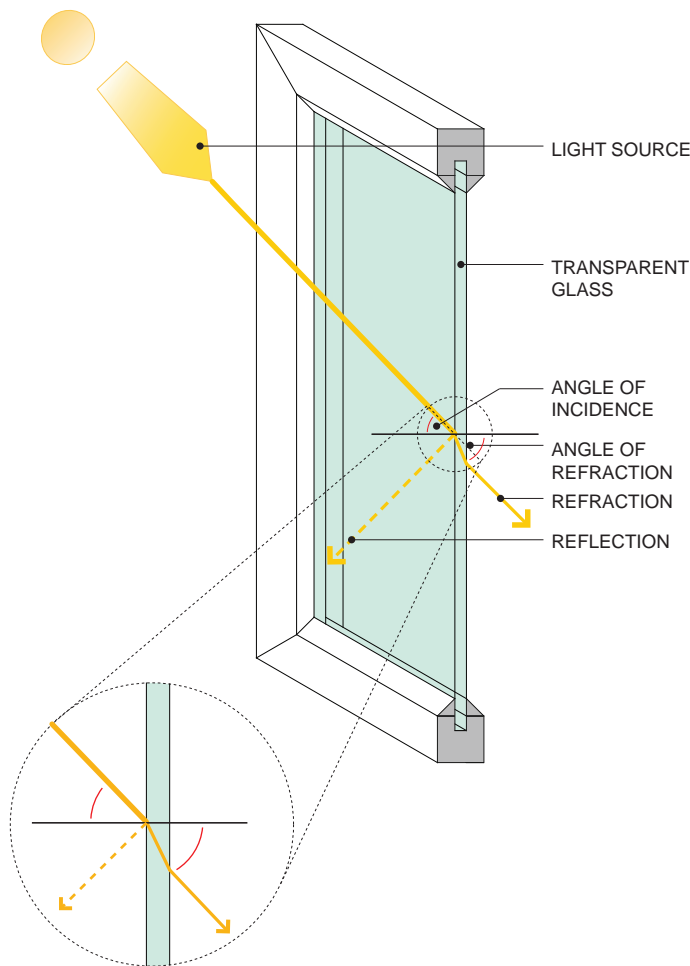

Fig. 6.1-8 Reflection and Refraction

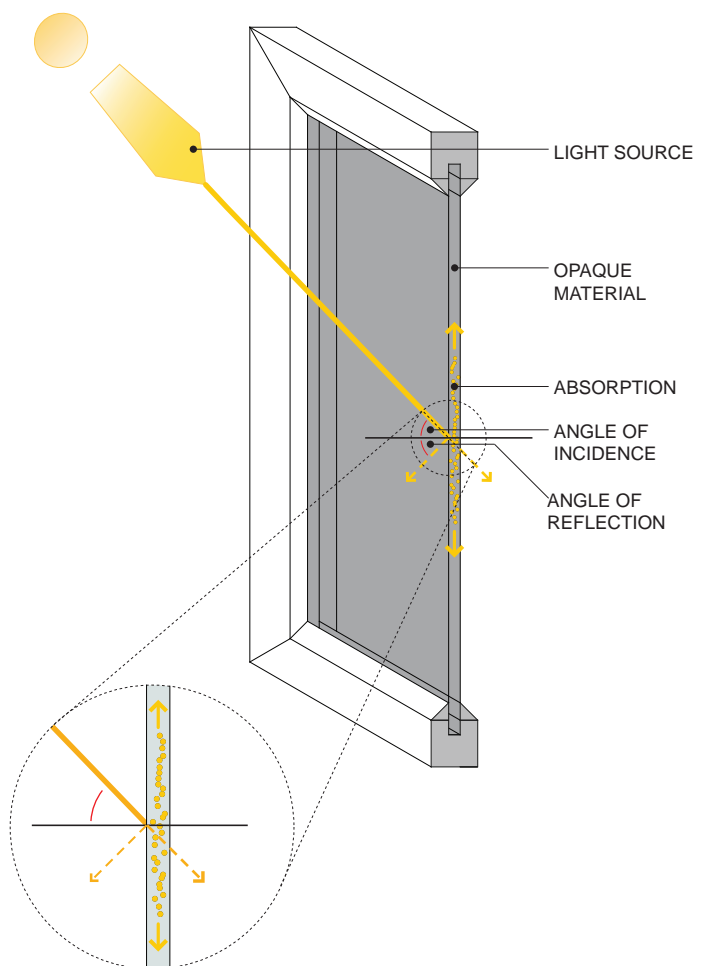
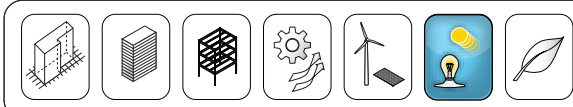

Fig. 6.1-9 Absorption



6. Lighting

Lighting Design

Lighting design demands an intricate balance of many competing requirements, such as providing visual comfort and acuity, and sense of orientation, meeting the building's programmatic and aesthetics needs, and minimizing energy consumption. Lighting distribution in a space should be appropriate and adaptable to the performed activities, to the time of day and to individual needs. A consideration of glare, reflectance, brightness, surface textures, color, and contrast is critical in lighting design to achieve visual age-based comfort, particularly in spaces occupied for extended periods.

GLARE Glare is one of the main factors in visual discomfort. Glare is produced by an excessively bright source of light within the visual field, either daylight or artificial light. Glare can also be created by a strong light reflection from surfaces in the space and in the surroundings such as windows and glass façades. Window openings and artificial light sources should be designed to minimize glare.

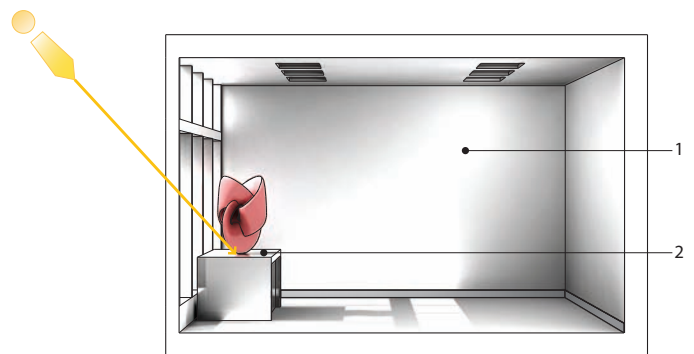

— Direct Lighting

1. Glare Reflected into Interior
2. Reflective Surface

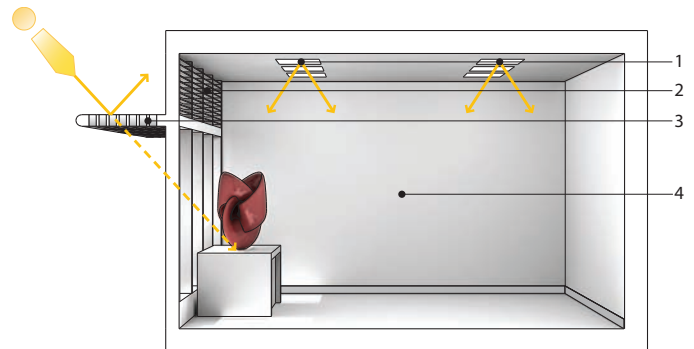

— Direct Lighting
 - - - Indirect Lighting

1. Uniform Electrical Light Distribution
2. Sun Screen
3. Sun Shade
4. Reduced Glare

Fig. 6.1-10 Glare

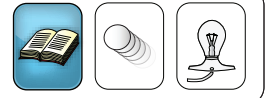

BRIGHTNESS Brightness is another factor that can contribute to visual discomfort. Brightness is dependent on how much light is emitted, reflected, or transmitted from an object. Brightness is a relative concept and becomes problematic when there are large differences between the brightness of various surfaces within a space. The brightness ratio consists of the ratio of the brightest surface to the least-bright surface in the field of vision. To avoid visual discomfort, the brightness ratio should not exceed 3:1.

CONTRAST Visual contrast refers to the relationship between the luminance of an object and its background. An object is distinguished from its background only if there is visual contrast. Some level of contrast may be desirable in a space for visual effectiveness, but excessive brightness contrast can cause visual discomfort. To reduce unwanted contrast, wall areas next to windows should be illuminated by another light source. In general, admitting light from multiple directions, rather than a single direction, will reduce contrast.

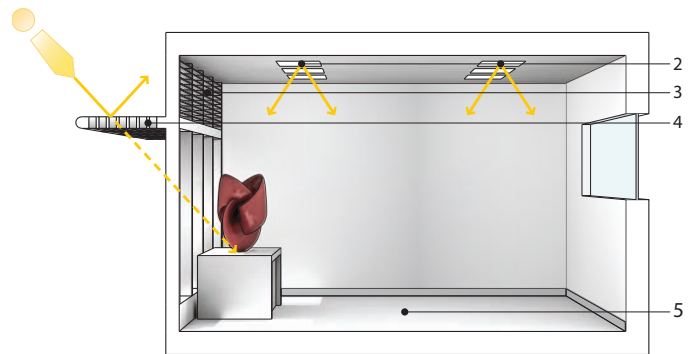
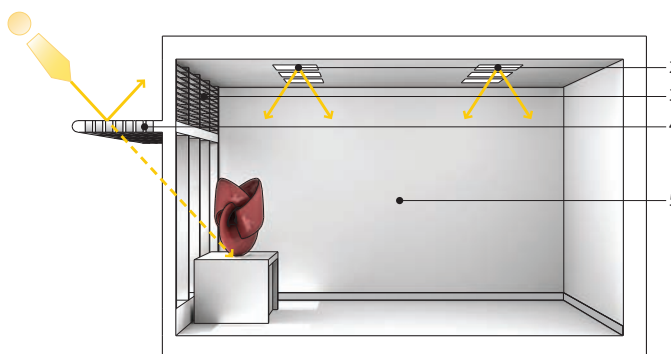
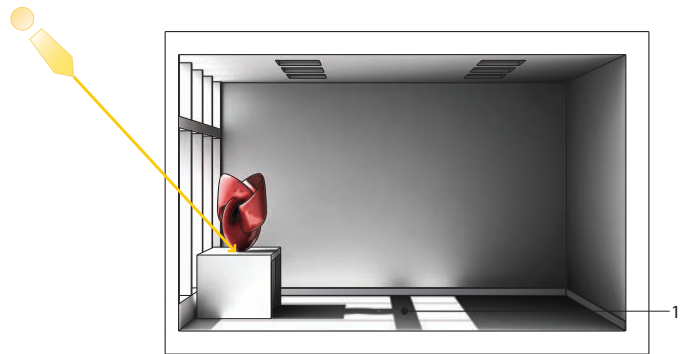
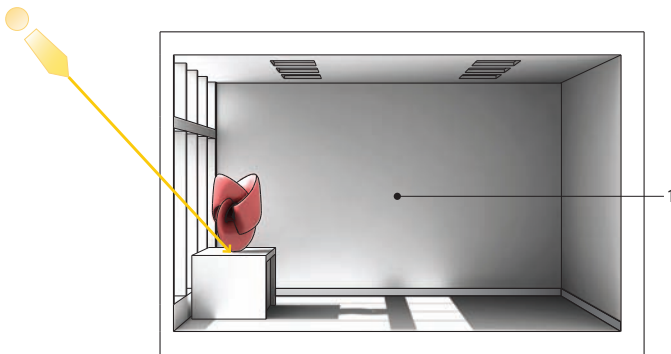

— Direct Lighting
 - - - Indirect Lighting

— Direct Lighting
 - - - Indirect Lighting

1. Irregular Natural Light Distribution
2. Uniform Electrical Light Distribution
3. Sun Screen
4. Sun Shade
5. Reduced Brightness

Fig. 6.1-11 Brightness

1. High Contrast
2. Uniform Electrical Light Distribution
3. Sun Screen
4. Sun Shade
5. Reduced Contrast

Fig. 6.1-12 Contrast